

LDL immune complexes stimulate LDL receptor expression in U937 histiocytes via extracellular signal-regulated kinase and AP-1

Yuchang Fu,^{1,†} Yan Huang,^{1,*} Sumita Bandyopadhyay,[†] Gabriel Virella,[§] and Maria F. Lopes-Virella^{2,*},[†]

Ralph H. Johnson Veterans Administration Medical Center,* Charleston, SC 29401; Division of Endocrinology, Diabetes and Medical Genetics, Department of Medicine,[†] and Department of Immunology and Microbiology,[§] Medical University of South Carolina, Charleston, SC 29425

Abstract We have previously shown that LDL-containing immune complexes (LDL-ICs) induce up-regulation of LDL receptor (LDLR) expression in human macrophages. The present study further investigated the molecular mechanisms leading to LDLR up-regulation by LDL-ICs as well as the signaling pathways involved. Results showed that treatment of U937 histiocytes with LDL-ICs did not increase the precursors and the cleaved forms of sterol-regulatory element binding proteins (SREBPs) 1a and 2, suggesting that SREBPs may not be involved in LDLR up-regulation by LDL-ICs. Promoter deletion and mutation studies showed that the AP-1 binding sites were essential for LDL-IC-stimulated LDLR expression. Electrophoretic mobility shift assays further demonstrated that LDL-ICs stimulated transcription factor AP-1 activity. Studies assessing the signaling pathways involved in LDLR up-regulation by LDL-ICs showed that the up-regulation of LDLR was extracellular signal-regulated kinase (ERK) dependent. **In conclusion,** the present study shows that LDL-ICs up-regulate LDLR expression via the ERK signaling pathway and the AP-1 motif-dependent transcriptional activation.—Fu, Y., Y. Huang, S. Bandyopadhyay, G. Virella, and M. F. Lopes-Virella. **LDL immune complexes stimulate LDL receptor expression in U937 histiocytes via extracellular signal-regulated kinase and AP-1.** *J. Lipid Res.* 2003. 44: 1315–1321.

Supplementary key words low density lipoprotein • mitogen-activated protein kinase • activator protein • macrophages • signal transduction

The transcription of LDL receptor (LDLR) is regulated by both intracellular cholesterol and extracellular stimuli such as cytokines, growth factors, and hormones. It has been well established that the intracellular cholesterol content regulates LDLR expression through a negative feedback mechanism (1, 2). When intracellular cholesterol is depleted, transcription factors sterol-regulatory element (SRE) binding proteins (SREBPs)-1 and -2 are escorted

from the endoplasmic reticulum into the Golgi and cleaved sequentially by proteases. The cleaved SREBP-1 and -2 enter nuclei, bind to the SRE-1, and initiate LDLR transcription. Conversely, when intracellular cholesterol is accumulated, the activation of SREBP-1 and -2 is inhibited and LDLR transcription is reduced. In addition to the intracellular cholesterol, LDLR transcription is also regulated by a variety of extracellular stimuli such as TNF α , IL-1 β (3), oncostatin M (4), TGF- β (5), and insulin (6). It has been known that the extracellular stimuli stimulate LDLR transcription through receptor-mediated signal transduction pathways. The signaling pathways that have previously been shown to be involved in LDLR expression include those leading to activation of protein kinase C or protein kinase A, and mobilization of intracellular Ca²⁺ (7, 8). Recently, several studies have reported that the mitogen-activated protein kinases (MAPKs) regulate LDLR transcription (3, 4, 6). The majority of the studies to date concerning signaling pathways and transcriptional mechanisms involved in LDLR expression have been conducted in hepatocytes. The information pertaining to the signaling regulation of LDLR expression in macrophages is very limited.

Although it has been well documented that macrophage scavenger receptors play an essential role in the transformation of macrophages into foam cells (9), the role of macrophage LDLR in atherogenesis should not be underestimated. A study (10) in which mice were transplanted with LDLR (^{-/-}) bone marrow to deplete LDLR expression in macrophages and fed a high-cholesterol diet showed that after 13 weeks, regardless of the increase in cholesterol levels, these mice developed 63% smaller lesions than those transplanted with LDLR (^{+/+}) bone marrow. Furthermore, it is known that LDLR mediates uptake of minimally oxidized LDL, whereas macrophage scavenger receptors only recognize extensively oxidized LDL (9). In the early stage

Manuscript received 21 October 2002 and in revised form 21 April 2003.

Published, *JLR Papers in Press*, May 14, 2003.

DOI 10.1194/jlr.M200415.JLR200

¹ Y. Huang and Y. Fu contributed equally to this work.

² To whom correspondence should be addressed.

e-mail: virellam@musc.edu

of atherogenesis, relatively few monocytes are present in the subendothelial space, and therefore it is unlikely that these cells could oxidize LDL to the extent that it would be recognized by the macrophage scavenger receptor (11). They may, however, contribute to the formation of minimally oxidized LDL, which can, in turn, lead to the expression of monocyte chemoattractant protein-1 and promote further recruitment of monocytes into the lesions (11). Therefore, we believe that macrophage LDLR, which can take up both minimally modified LDL and native LDL, may play an important role in the early stage of atherogenesis.

LDL-containing immune complexes (LDL-ICs) are present in atherosclerotic plaques (12). Our previous studies have shown that LDL-IC up-regulated LDLR transcription in human monocyte-derived macrophages and macrophage-like cells (13, 14). Recently, we have investigated the signaling and transcriptional mechanisms involved in LDL-IC-stimulated LDLR expression. We found that the up-regulation of LDLR transcription by LDL-IC is mediated by the extracellular signal-regulated kinase (ERK) signaling pathway. Our data also suggested that transcription factor AP-1, activated by the ERK signaling pathway, may target distal AP-1 binding sites situated at -125 and -232 in the LDLR promoter region, and stimulate LDLR transcription. Thus, the present study has elucidated a unique signaling and transcription mechanism controlling LDLR expression in macrophages.

METHODS

Cell culture

U937 histiocytes were cultured in a 5% CO₂ atmosphere in Iscove's modified Dulbecco's medium supplemented with 10% fetal calf serum, according to the instructions from American Type Culture Collection (Manassas, VA). The medium was changed every 2–3 days. The histiocytic (resident macrophage) origin of U937 cells was confirmed by their capacity for lysozyme production and strong esterase activity.

Isolation of lipoprotein and preparation of insoluble immune complexes

LDL (1.019–1.063) was isolated from the plasma of normal volunteers and oxidatively modified as described (15). Insoluble LDL-ICs were prepared with human native LDL and rabbit anti-LDL antiserum as described previously (13, 15). The insoluble LDL-ICs were washed three times with PBS, and the protein content of LDL-ICs was determined by the Lowry protein assay (16). The endotoxin level in LDL-IC preparations was measured using an endotoxin assay kit (Sigma, St. Louis, MO), and the level was found to be below the lower limit of detection (0.015 U/ml).

Real-time PCR

Five micrograms of the total RNA was converted to the first-strand cDNA using random primers (Gibco BRL, Rockville, MD). Real-time PCR was performed using an iCycler iQ real-time PCR detection system (Bio-Rad Laboratories, Inc., Hercules, CA) and iQ SYBR Green Supermix buffer (100 mM KCl, 40 mM Tris-HCl, 0.4 mM of each dNTP, 6 mM MgCl₂, SYBR Green I), which contains a hot-start iTaq DNA polymerase (50 U/ml) and 20 nM of fluorescein. The concentrations of the primers for LDLR (GCTGTGCTGTCACCTGCAAA/AAGTCCGAGAGATGCACTT) were 500 nM. One milliliter of the first-strand cDNA was used for each

50 µl of real-time PCR reaction. The PCR thermal cycling program was: 3 min at 95°C for enzyme activation (allowing hot start), 45 cycles of 30 s at 95°C for denature, 30 s at 60°C for annealing, and 30 s at 72°C for extension. The melting curve analysis was performed to confirm the real-time PCR products. The amplified products were denatured and reannealed at different temperature points to detect their specific melting temperature.

Promoter reporter gene constructs

Human genomic DNA was isolated from U937 cells. A fragment of the LDLR 5' flanking region, from -367 to +88, was amplified by PCR. The fragment was subcloned into pCR2.1 vector (Invitrogen, Carlsbad, CA). This clone was used as a parental clone for PCR amplification of four 5' deleted promoter fragments that were also subcloned into pCR2.1 vectors. All fragments were sequenced to ensure fidelity of PCR amplification. After propagation in bacteria, the fragments were subcloned in sense orientation into the *KpnI/HindIII* sites of luciferase reporter pGL3-Basic vector (Promega, Santa Clarita, CA). The plasmids were isolated from bacteria using endotoxin-free plasmid isolation kits (Qiagen).

Transient transfection of U937 cells

U937 cells grown in a 35 mm dish were transfected for 24 h with 1 µg of each promoter-reporter construct and 1 µg of pSVβGal vector using transfection reagent FuGene 6, according to the instructions given by the manufacturer (Roche Molecular Biochemicals, Indianapolis, IN). After the transfection, the cells were incubated with or without LDL-ICs for 2 h. The cells were then lysed, and cellular luciferase and β-galactosidase activities were measured by the luciferase and the β-galactosidase activity assay kits (Promega). The ratios of luciferase activity to β-galactosidase activity were calculated to adjust the transfection efficiency of the constructs. U937 cells were also transfected with pcDNA3-Ras 17N, pcDNA3-Raf 301, or negative dominant Ras or Raf mutants (17) as well as pcDNA empty vector. These plasmids were kindly provided by Dr. John Raymond at the Medical University of South Carolina.

Western blot analysis of ERK, LDLR, and SREBPs

Phosphorylation of ERK was detected by Western blot analysis using monoclonal antiphosphorylated and anti-p43/p44 MAPK antibodies as described previously (15). Briefly, U937 cells were lysed after LDL-IC stimulation with lysis buffer containing 20 mM Tris, pH 8.0, 130 mM NaCl, 10% glycerol, 10 mM Chaps, 0.1 U/ml aprotinin, 0.156 mg/ml benzamidine, 2 mM vanadate, and 1 mM PMSF. An aliquot of the cell protein extract (25 µg) was electrophoresed in 10% polyacrylamide gel and transferred to polyvinylidene difluoride (PVDF) membranes (NEN Life Science Products, Boston, MA). The membranes were incubated with blocking buffer containing 20 mM Tris, pH 7.6, 130 mM NaCl, 0.1% Tween-20, and 5% nonfat dry milk for 1 h at room temperature. The membrane was then incubated with anti-phosphorylated or anti-p42/p44 MAPK antibodies (1:1,000 dilution) for 1 h at room temperature, followed by incubation with horseradish peroxidase-conjugated rabbit anti-mouse IgG (1:5,000 dilution) for 1 h at room temperature. The ERK1/2 were visualized by incubating the membrane with chemiluminescence reagents for 1 min and then exposing it to X-ray film for 15–30 s. To detect LDLR protein, monoclonal anti-LDLR antibody 4A4 (1:100 dilution) and anti-mouse IgG (1:3,000 dilution) were used for blotting. In the Western blot analysis of SREBPs, monoclonal anti-SREBP-1a and SREBP-2 antibodies (1:1,000 dilution) (BD Pharmingen, San Diego, CA) were used.

Electrophoretic mobility shift assay

Binding activity of AP-1 in human U937 macrophages stimulated by LDL-ICs was examined using electrophoretic mobility

shift assay (EMSA). U937 cells were washed twice with ice-cold PBS and then pelleted by centrifugation at 13,800 *g* for 1 min. The cell pellet was resuspended in 400 μ l of Buffer 1 [10 mM HEPES, pH 7.9, 10 mM KCl, 0.1 mM ethylenediaminetetraacetic acid (EDTA), 0.1 mM dithiothreitol, 1% (w/v) mammalian protease inhibitor cocktail solution (Sigma)] and placed on ice to swell for 15 min. After addition of 25 μ l of 10% (w/v) Nonidet P-40, the samples were vortexed for 10 s and then centrifuged at 13,800 *g* for 20 s. The cell pellets were resuspended in 50 μ l of Buffer 2 [20 mM HEPES, pH 7.9, 25% (w/v) glycerol, 0.4 M NaCl, 1 mM EDTA, 1 mM dithiothreitol, 1% (w/v) mammalian protease inhibitor cocktail solution (Sigma)]. After vortexing, the cell suspension was homogenized on ice and centrifuged at 13,800 *g* for 15 min at 4°C. The supernatant containing the nuclear proteins was stored at -70°C.

The oligonucleotide sequence containing the AP-1 consensus (Promega) was 5'-CGCTTGATGAGTCAGCCGGAA-3'. Oligonucleotides were labeled with [³²P]ATP using T4 polynucleotide kinase (Promega). Five micrograms of the nuclear extract was incubated with 10 μ l of reaction mixture containing 5% glycerol, 1 mM MgCl₂, 0.5 mM EDTA, 0.5 mM dithiothreitol, 50 mM NaCl, 10 mM Tris-HCl, pH 7.5, 0.05 mg/ml poly(dI-dC)·poly(dI-dC), and 0.035 pmol of radiolabeled oligonucleotides. The reactions were carried out at room temperature for 20 min. After addition of 1 μ l of gel-loading buffer (250 mM Tris-HCl, pH 7.5, 0.2% bromophenol blue, 40% glycerol), the reaction products were analyzed on a 4% polyacrylamide gel, and the radioactive bands were visualized by autoradiography. Competition studies using 50-fold unlabeled AP-1, SP-1 (5'-ATTCGATCGGGGCGGGCG-AGC-3'), or NF κ B (5'-AGTTGAGGGGACTTTCCAGGC-3') oligonucleotides were performed to ensure the binding specificity of AP-1. For supershift assay, the radiolabeled AP-1 oligonucleotides were incubated with nuclear extract in the presence or absence of 1 μ g of anti- ϵ Jun antibody (Santa Cruz Biotechnology, Inc., Santa Cruz, CA) and the mixture was electrophoresed as described above.

In vitro site-directed mutagenesis

Mutagenesis of the AP-1 site was performed using a GeneEditor™ In Vitro Site-directed Mutagenesis System (Promega) according to the manufacturer's instructions. Two mutagenic oligonucleotides, LDLR-AP1-A (5'-CAATTTTGAGGGGGCATATGCTCTT-CACCGAGAC-3') and LDLR-AP1-B (5'-CGGGTTAAAAAGCCG-ATATATCATCGGCCGTTTCG-3'), were prepared for generating the mutated constructs. (The sequences underlined are the mutated bases in the AP-1 motif.) The mutations of the AP-1 motifs were confirmed by DNA sequence analysis.

RESULTS

LDL-ICs stimulate LDLR transcription in U937 cells

We have shown previously that LDL-ICs stimulated LDLR expression in human macrophages (13, 14). To determine whether U937 cells respond to LDL-ICs in a similar manner, we assessed the level of LDLR mRNA expression in the cells following stimulation with LDL-ICs using real-time PCR. Results showed that LDLR mRNA expression was increased by 50% in control cells after 2 h incubation and returned to baseline levels at 8 and 24 h. (Ratios of LDLR mRNA vs. 18s rRNA copy number of molecules were 95,000 \pm 4,850 at time 0 and 140,000 \pm 8,400 at 2 h.) The increase in the LDLR mRNA expression observed at 2 h in control cells was probably due to the

fact that addition of fresh medium at time 0 led to enhanced cholesterol efflux (more cholesterol acceptors such as HDL and phospholipids in the fresh medium) and, as a consequence, to up-regulation of LDLR expression. This effect seems to be transient, because LDLR mRNA expression in control cells returned to baseline levels at 8 h, probably due to saturation of the cholesterol acceptors. In contrast, treatment of cells with LDL-ICs further increased LDLR mRNA expression by 60% at 2 h and by 50% at 8 and 24 h (Fig. 1A). Western blot showed that LDL-ICs markedly increased cellular LDLR protein level (Fig. 1B). The discrepancy between the increase in LDLR mRNA and that in LDLR protein is consistent with our previous study showing that LDL-ICs up-regulate LDLR gene expression at both the transcriptional and posttranscriptional levels (14). Because the stimulation of LDLR expression by LDL-ICs at 2 h was greater than that at 8 and 24 h, we chose 2 h as the stimulation time in all experiments that followed.

To determine whether LDL-ICs increased LDLR mRNA through transcriptional activation, U937 cells were trans-

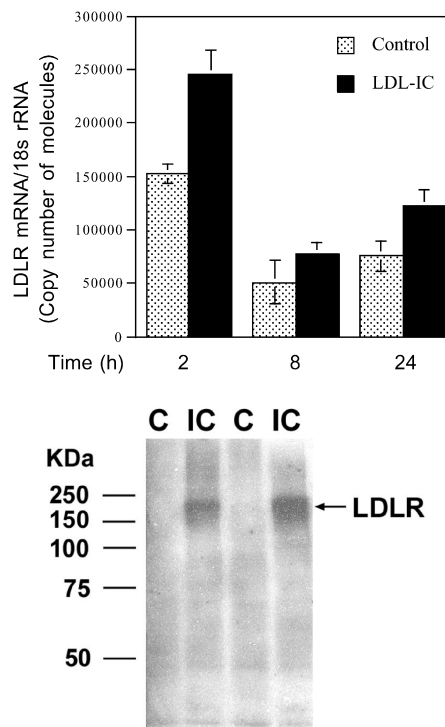

Fig. 1. Top: Real-time PCR analysis of the effect of LDL-containing immune complexes (LDL-ICs) on LDL receptor (LDLR) mRNA expression. U937 cells were treated with or without 150 μ g/ml of LDL-ICs for 2, 8, and 24 h. Total RNA was isolated, and 5 μ g of the RNA was converted to cDNA using random primers. The real-time PCR was performed as described in Methods. The ratio of the mRNA copy number of LDLR to that of 18s rRNA was calculated and presented. Error bars indicate SEM. Bottom: Western blot analysis of cellular LDLR protein level. U937 cells were lysed after treatment with 150 μ g/ml of LDL-ICs for 2 h, and protein extract was analyzed for LDLR by Western blot as described in Methods. The Western blot was conducted with duplicate samples. The data presented are representative of two independent experiments with similar results.

ected with a promoter-reporter construct prepared by inserting an LDLR promoter fragment (−367+88) into the 5′ flanking region of the luciferase coding sequence in the pGL3-Basic vector. The transfected cells were then treated with LDL-ICs. Luciferase activity assay showed that LDL-ICs stimulated luciferase activity in the transfected cells (Fig. 2), suggesting that LDL-ICs activated LDLR transcription.

The effect of LDL-ICs on the SRE activation

The SRE in the LDLR promoter region has been shown to be essential for the regulation of LDLR expression by sterol and other mediators (1, 2, 6). To determine whether the SRE was also involved in LDLR expression stimulated by LDL-ICs, the cellular levels of SREBPs in response to LDL-IC stimulation were determined by Western blot. Results showed that LDL-ICs did not stimulate either the precursors (membrane bound) or the matured forms (in nuclear extracts) of SREBP-1a and SREBP-2 in U937 cells (Fig. 3A). To demonstrate that the SREBPs were responsive to the extracellular stimulus, the cells were treated with or without LDL in the lipoprotein-deficient serum (LPDS)-containing medium. Results showed that the matured forms of SREBP-1a and SREBP-2 in cells treated with LPDS-containing medium alone were markedly increased as compared with those in cells treated with LDL (Fig. 3B). These results suggest that SREBPs may not be involved in LDL-IC-stimulated LDLR expression.

LDL-IC stimulation is mediated through AP-1 binding sites in the LDLR promoter region

To localize the *cis*-acting element(s) responsible for LDL-IC stimulation, deletion analysis was performed with five promoter-reporter constructs containing serial 5′-deleted

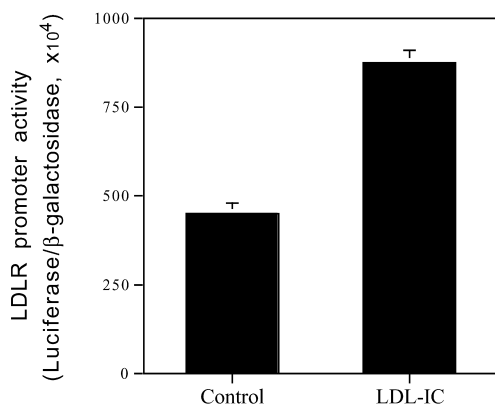

Fig. 2. Transcriptional activation of LDLR by LDL-IC. Construct 1 was prepared by insertion of a fragment of LDLR promoter (−367+88) into *KpnI/HindIII* sites of the luciferase reporter pGL3-Basic vector. U937 cells were transfected with Construct 1 using FuGene 6 as transfection reagent for 24 h. After the transfection, the cells were treated with or without 150 μg/ml of LDL-IC for 2 h, and luciferase activity was then measured. The cells were cotransfected with β-galactosidase vector, an internal control for the transfection efficiency. The ratios of luciferase activity to β-galactosidase activity were calculated. Data (mean ± SD) presented are representative of three independent experiments with similar results.

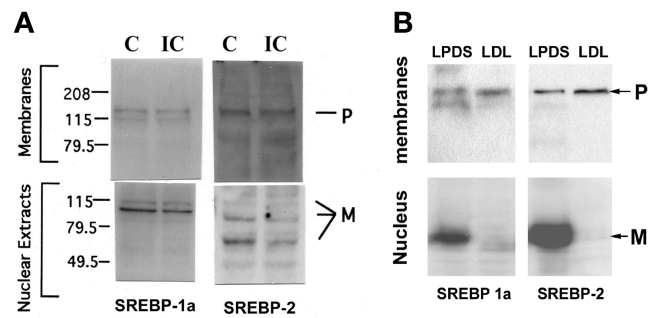

Fig. 3. The effect of LDL-ICs on sterol-regulatory element binding protein (SREBP) levels in U937 cells. U937 cells were incubated with LDL-ICs for 2 h and then lysed. Membrane and nucleus-associated SREBP 1a and SREBP 2 were detected by Western blot using monoclonal antibody IgG-2A4 (anti-SREBP-1a) and IgG-7D4 (anti-SREBP-2) (A). For control, the cells were treated with 10% lipoprotein-deficient serum (LPDS) in the absence of presence of 200 μg/ml LDL for 48 h, and membrane and nucleus-associated SREBP-1a and SREBP-2 were detected by Western blot (B). C, control; IC, LDL-ICs; P, precursor; M, matured protein.

LDLR promoter fragments (Fig. 4). Results showed that LDL-ICs stimulated luciferase activity in cells transfected with Construct 1 or 2 (Fig. 4). Quite interestingly, however, the baseline expression of LDLR (see control cells) was decreased in cells transfected with Construct 2. These results suggest that the *cis*-acting elements that are critical for LDL-IC stimulation may be located between −367 and −105 in the LDLR promoter region. Because these elements are absent in Constructs 3–6, no stimulation of LDLR promoter activity by LDL-ICs was found when cells were transfected with these constructs. By analyzing the *cis*-acting elements in the promoter region between −367 and −105, two AP-1 binding sites at −232 and −125 were found. To determine if these AP-1 motifs are responsible for LDL-IC-stimulated LDLR expression, promoter-reporter constructs that contain mutations in these AP-1 motifs were prepared for mutation analysis. Results showed that, as compared with the wild-type Construct 1, the mutations in either −232 or −125 AP-1 motifs not only completely abolished up-regulation of LDLR by LDL-ICs, but also inhibited more than 50% of the baseline level of LDLR promoter activity (Fig. 5). These mutation studies indicate that both −232 and −125 AP-1 motifs are involved in LDLR expression in both control and LDL-IC-treated cells.

LDL-ICs stimulate transcription factor AP-1 activity

Because the above study showed that LDL-IC-stimulated LDLR promoter activity is AP-1 motif dependent, we determined whether LDL-ICs stimulate transcription factor AP-1 activity. Our data from the EMSA showed that LDL-IC treatment markedly increased AP-1 activity (Fig. 6A). The specific binding of AP-1 transcription factor to the AP-1 consensus sequence-containing oligonucleotides is indicated by results showing that the addition of unlabeled AP-1 oligonucleotides completely abolished the shift, whereas unlabeled SP-1 and NFκB consensus sequence-containing oligonucleotides had no effect (Fig. 6A). Moreover, addi-

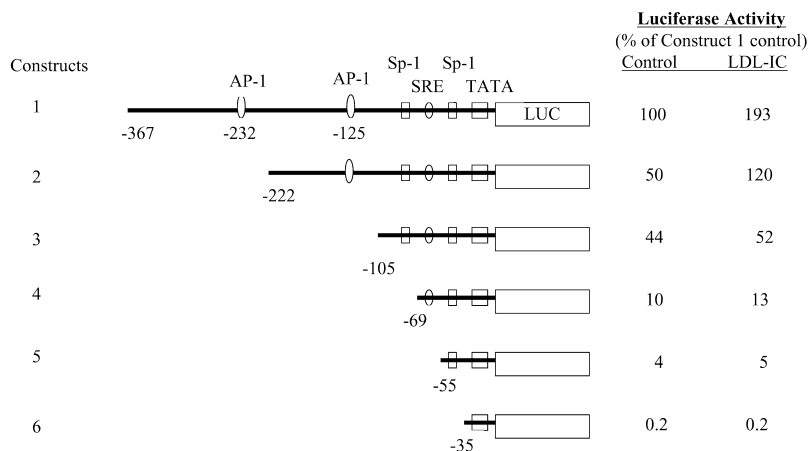

Fig. 4. The effect of LDL-ICs on LDLR promoter activity. U937 cells were transiently transfected for 24 h with Constructs 1–6 as depicted in the figure and then treated with or without 150 $\mu\text{g}/\text{ml}$ of LDL-IC for 2 h. The relative luciferase activity was then measured as described in Methods and corrected for transfection efficiency. The luciferase activity in the control cells transfected with Construct 1 was designated as 100%, and the rest of the data are presented as percentage of the activity. The data are averages of four experiments. The standard deviations of all samples are less than 15% of means. SRE, sterol-regulatory element; LUC, luciferase.

tion of anti- ϵ -Jun antibody led to a supershift (Fig. 6B), further indicating that AP-1 is the transcription factor bound to the AP-1 element in the radiolabeled oligonucleotides.

ERK signaling pathway is responsible for LDL-IC-stimulated LDLR transcription

Recent studies have shown that the ERK signaling pathway plays an important role in LDLR expression (3, 4, 6) and that activation of the ERK signaling pathway stimulates transcription factor AP-1 (18). Thus, we determined whether the ERK pathway mediates LDL-IC-stimulated LDLR expression in U937 cells. In this experiment, U937 cells were transfected with Constructs 1–3 and then stimulated with LDL-ICs for 2 h in the presence or absence of PD98059, a specific MAPK/ERK kinase (MEK) inhibitor. Luciferase activity assay clearly showed that PD98059 completely abrogated LDL-IC-stimulated LDLR promoter activity (Fig. 7). To confirm the involvement of the ERK sig-

naling pathway in LDL-IC-stimulated LDLR expression, we also targeted Raf-1 and Ras, two upstream components in ERK activation (18), by the dominant negative approach. Results showed that transfection of U937 cells with the mutant vectors of Raf-1 (Raf 301) and Ras (Ras17N) (17) not only completely abrogated LDL-IC stimulation, but also significantly inhibited basal LDLR promoter activity (Fig. 8), suggesting that both baseline expression and LDL-IC-stimulated expression of LDLR

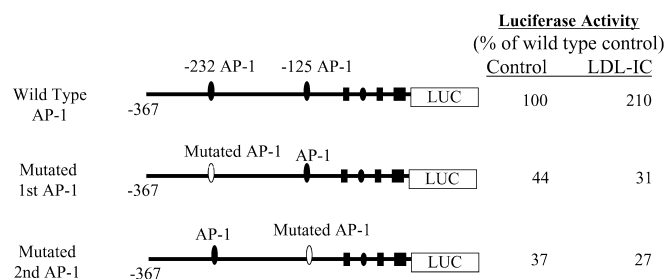

Fig. 5. The effect of the AP-1 binding site mutation on LDLR promoter activity. U937 cells were transfected with the wild-type Construct 1 or with the constructs containing mutated AP-1 binding sites (–232 or –125) for 24 h and then treated with or without 150 $\mu\text{g}/\text{ml}$ of LDL-IC for 2 h. The luciferase activity was measured as described in Methods. The luciferase activity in the cells transfected with the wild-type Construct 1 is designated as 100%. The data presented are representative of three experiments with similar results. The standard deviations of all samples are less than 15% of means.

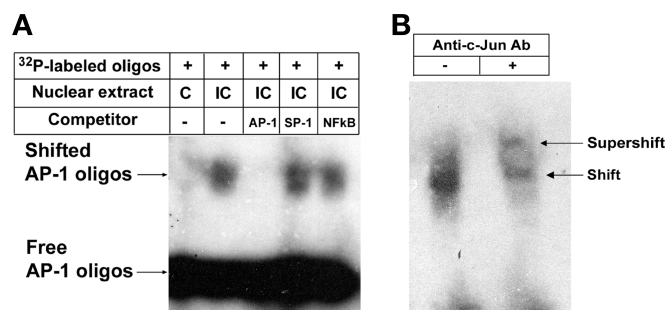

Fig. 6. Stimulation of AP-1 DNA binding activity by LDL-ICs. U937 cells were treated with or without 150 $\mu\text{g}/\text{ml}$ LDL-IC for 2 h, and nuclear proteins were then extracted. The nuclear extracts were incubated with the radiolabeled AP-1 oligonucleotide for 1 h, and the mixture was subjected to electrophoresis in 4% polyacrylamide gel under nondenatured conditions (A). The gel was dried, and the autoradiogram was exposed to the dried gel. Lane 1, nuclear proteins extracted from control cells; Lane 2, nuclear proteins extracted from LDL-IC-treated cells; Lane 3, 50-fold unlabeled AP-1 oligonucleotides were mixed with the radiolabeled AP-1 oligonucleotides before incubation with nuclear proteins extracted from control cells; Lane 4, 50-fold unlabeled SP-1 oligonucleotides were mixed with the radiolabeled AP-1 oligonucleotides; Lane 5, 50-fold unlabeled NF κ B oligonucleotides were mixed with the radiolabeled AP-1 oligonucleotides. For the supershift assay (B), the radiolabeled AP-1 oligonucleotides were incubated with nuclear extract in the absence or presence of anti- ϵ -Jun antibody (1 μg), and the mixture was electrophoresed as described above.

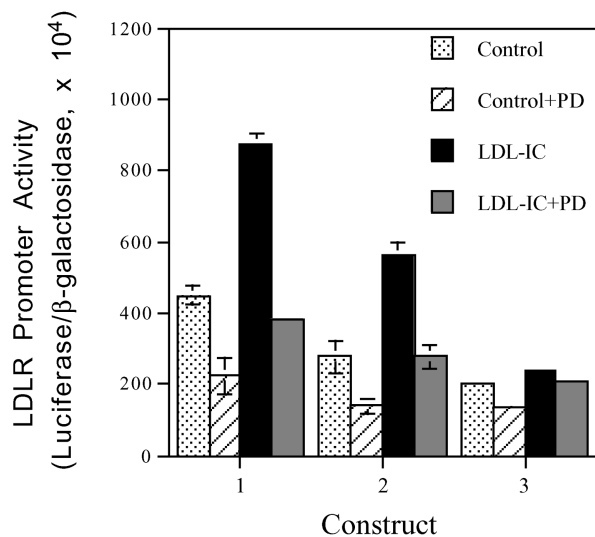

Fig. 7. Inhibition of LDLR promoter activity by PD98059. U937 cells were transfected with Constructs 1–3 and then treated with 150 $\mu\text{g}/\text{ml}$ of LDL-IC for 2 h in the presence or absence of 50 μM PD98059. After the treatment, luciferase activity was measured and corrected for transfection efficiency. Data (mean \pm SD) are representative of three experiments with similar results.

are Raf-1 and Ras dependent. Following these observations, the effect of LDL-IC on ERK phosphorylation was further determined. Results show that LDL-IC stimulated ERK phosphorylation in a time-dependent manner and that the peak stimulation occurred at 40 min (Fig. 9).

DISCUSSION

Several recent studies have demonstrated that MAPK signaling pathways mediate up-regulation of LDLR expression by cytokine, insulin, and other agents (3, 4, 19, 20). Mehta and coworkers reported that both the p38 and ERK pathways were involved in the TNF α - and IL-1 β -regulated LDLR expression in HepG2 cells (3, 21). However, these studies did not illustrate the MAPK-targeted transcription factors and LDLR promoter element(s) responsible for LDLR expression. Using the same cell line, Liu and coworkers showed that p42/p44 MAPK mediated oncostatin M-stimulated LDLR expression via the repeat 3 (the second SP-1 binding site) in the LDLR promoter (4). Kotzka et al. reported that the JNK/SAPK MAPK signaling pathway mediated cytokine-up-regulated LDLR expression via SREBP-1a (19). Collectively, these studies indicate that MAPK activation leads to the up-regulation of LDLR in human hepatocytes.

The present study investigated the signaling mechanism involved in the LDL-IC-stimulated LDLR expression in human macrophage-like U937 cells. Our results demonstrated for the first time that LDL-ICs activate ERK signaling pathways that up-regulate AP-1-mediated LDLR expression. Although our study also demonstrates the importance of ERK signaling pathways in LDLR expression, there is a major difference between our current study and the reports described above. Our study showed that two

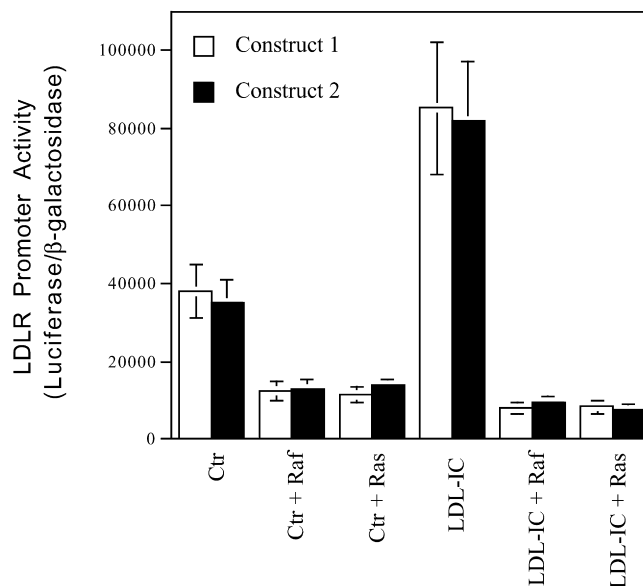

Fig. 8. Raf- and Ras-dependent stimulation of LDLR transcriptional activity induced by LDL-IC. U937 cells were cotransfected with Raf 301 or Ras17N and Construct 1 (open bars) or Construct 2 (filled bars) for 24 h and then stimulated with or without 150 $\mu\text{g}/\text{ml}$ of LDL-IC for 2 h. The luciferase activity was then measured as described in Methods. Data represent mean \pm SEM of three experiments.

AP-1 binding sites were the *cis*-acting elements responsible for LDLR expression, whereas others showed that the classic elements (Sp-1 and SRE) in the proximal region of the promoter are the responsive elements. This difference clearly indicates that the ERK signaling pathway is capable of targeting different *cis*-acting elements in the LDLR promoter in response to different stimulators.

In our deletion and mutation studies, we found that the mutation of the -232 AP-1 binding site in Construct 1 inhibited both basal and LDL-IC-stimulated LDLR promoter activity (Fig. 5). However, a 2-fold stimulation was observed in cells transfected with the wild-type Construct 2 that had deleted the AP-1 binding site at -232 (Fig. 4). To explain why the mutation, but not the deletion, of the -232 AP-1 binding

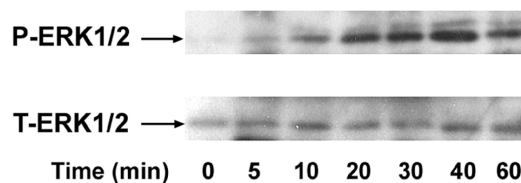

Fig. 9. Time-dependent stimulation of mitogen-activated protein kinase/extracellular signal-regulated kinase (MAPK/ERK) kinase (MEK) in U937 cells by LDL-ICs. U937 cells were stimulated with 150 $\mu\text{g}/\text{ml}$ LDL-IC for the times indicated and then lysed. Twenty-five micrograms of cell protein was electrophoresed on a 10% SDS polyacrylamide gel and then transferred to a polyvinylidene difluoride membrane. The membrane was immunoblotted with anti-phosphorylated or anti-p42/p44 MAPK antibodies as described in Methods. MAPK was visualized by incubating the membrane with chemiluminescence reagent for 1 min and exposure to X-ray film for 15 s. Data are representative of three experiments with similar results. P-ERK, phosphorylated ERK; T-ERK, total ERK.

site inhibits LDLR promoter activity, we would like to postulate that an unknown repressive element may be present in the same region (from -367 to -222), which is normally suppressed by the -232 AP-1 binding site. When the -232 AP-1 binding site is mutated, the repressive element dominates and prevents the stimulation of the LDLR promoter activity by LDL-ICs. However, in the wild-type Construct 2, because the repressive element is deleted, LDL-ICs are able to stimulate the LDLR promoter activity through the -125 AP-1 binding site, although the basal and LDL-IC-stimulated promoter activities are about 50% less than those observed in cells transfected with the wild-type Construct 1 (see Fig. 4).

Transcription factor AP-1 is composed of members of the Jun and Fos families that associate to form either homo- or heterodimers (18). As the "immediate-early" genes, both *c-fos* and *c-jun* are rapidly stimulated transcriptionally upon MAPK activation. Our EMSA clearly demonstrated that LDL-IC stimulated AP-1 activity in U937 cells. The involvement of AP-1 in LDLR expression stimulated by LDL-ICs is evidenced by the mutation studies showing that the mutations in the AP-1 binding sites in the LDLR promoter region completely abolished the LDL-IC-stimulated LDLR promoter activity. Also interesting is the fact that the baseline expression of LDLR is also inhibited by the mutations, suggesting that the AP-1 motif may be important for the basal expression of the receptor as well. Given that the culture medium contains 10% fetal bovine serum, and the *c-fos* expression has been shown to be up-regulated by serum through the serum-response element (18), it is possible that the basal expression of LDLR in control cells is also mediated by the ERK signaling pathway.

In conclusion, the present study has revealed a stimulatory pathway elicited by LDL-ICs for LDLR expression: LDL-ICs activate the ERK cascade that, in turn, stimulates AP-1 transcription factor; AP-1 binds to the AP-1 motifs in the LDLR promoter region and hence activates LDLR transcription. To the best of our knowledge, all *cis*-acting elements for LDLR transcription reported to date were found to be one or more of the proximal three repeats (1). Therefore, the present study documented for the first time the role of the AP-1 binding sites in LDLR transcription. ■

This work was supported by V.A. Merit Review Grants (M.F.L.-V., Y.H.), Grants HL-55782 and HL-46815 from the National Institutes of Health (M.F.L.-V.), and an American Heart Association grant-in-aid (M.F.L.-V.). This work was also partially supported by National Institutes of Health COBRE Grant P20 PR-16434 (Y.F.). The authors thank Dr. John Raymond at the Medical University of South Carolina for providing Ras17N and Raf 301 mutant plasmids, Drs. Kathleen Meier and Dennis Watson for their invaluable comments, and Dr. Alejandro Maldonado and Mrs. Charlyne Chassereau for their excellent technical assistance.

REFERENCES

- Goldstein, J. L., S. K. Basu, and M. S. Brown. 1983. Receptor-mediated endocytosis of low-density lipoprotein in cultured cells. *Meth. Enzymol.* **98**: 241-260.
- Goldstein, J. L., and M. S. Brown. 1990. Regulation of the mevalonate pathway. *Nature.* **343**: 425-430.
- Kumar, A., A. Middleton, T. C. Chambers, and K. D. Mehta. 1998. Differential roles of extracellular signal-regulated kinase-1/2 and p38 MAPK in interleukin-1b and tumor necrosis factor A-induced low density lipoprotein receptor expression in HepG2 cells. *J. Biol. Chem.* **273**: 15742-15748.
- Li, C., F. B. Kraemer, T. E. Ahlborn, and J. Liu. 1999. Induction of low density lipoprotein receptor (LDLR) transcription by oncostatin M is mediated by the extracellular signal-regulated kinase signaling pathway and the repeat 3 element of the LDLR promoter. *J. Biol. Chem.* **274**: 6747-6753.
- Nicholson, A. C., and D. P. Hajjar. 1992. Transforming growth factor beta upregulates low density lipoprotein receptor-mediated cholesterol metabolism in vascular smooth muscle cells. *J. Biol. Chem.* **267**: 25982-25987.
- Streicher, R., J. Kotzka, D. Muller-Wieland, G. Siemeister, M. Munck, H. Avci, and W. Krone. 1996. SREBP-1 mediates activation of the low density lipoprotein receptor promoter by insulin and insulin-like growth factor-1. *J. Biol. Chem.* **271**: 7128-7133.
- Kumar, A., T. C. Chambers, B. A. Cloud-Hefflin, and K. D. Mehta. 1997. Phorbol ester-induced low-density lipoprotein receptor gene expression in HepG2 cells involves protein kinase C-mediated p42/44 MAP kinase activation. *J. Lipid Res.* **38**: 2240-2248.
- Auwerx, J. H., A. Chait, G. Wolfbauer, and S. S. Deeb. 1989. Involvement of second messengers in regulation of the low-density lipoprotein receptor gene. *Mol. Cell. Biol.* **9**: 18194-18199.
- Parthasarathy S., N. Santanam, S. Ramachandran, and O. Meilhan. 1999. Oxidants and antioxidants in atherogenesis: an appraisal. *J. Lipid Res.* **40**: 2143-2157.
- Linton, M. F., V. R. Babaev, L. A. Gleaves, and S. Fazio. 1999. A direct role for the macrophage low density lipoprotein receptor in atherosclerotic lesion formation. *J. Biol. Chem.* **274**: 19204-19210.
- Liao, F., J. A. Berliner, M. Mehrabian, M. Navab, L. L. Demer, A. J. Lusis, and A. M. Fogelman. 1991. Minimally modified low density lipoprotein is biologically active in vivo in mice. *J. Clin. Invest.* **87**: 2253-2257.
- Yla-Herttuala, S., W. Palinski, S. W. Butler, S. Picard, D. Steinberg, and J. L. Witztum. 1994. Rabbit and human atherosclerotic lesions contain IgG that recognizes epitopes of oxidized LDL. *Arterioscler. Thromb.* **14**: 32-40.
- Griffith, R. L., G. T. Virella, H. C. Stevenson, and M. F. Lopes-Virella. 1988. Low density lipoprotein metabolism by human macrophages activated with low density lipoprotein immune complexes. *J. Exp. Med.* **168**: 1041-1059.
- Huang, Y., M. J. Ghosh, and M. F. Lopes-Virella. 1997. Transcriptional and post-transcriptional regulation of LDL receptor gene expression in PMA-treated THP-1 cells by LDL-containing immune complexes. *J. Lipid Res.* **38**: 110-120.
- Huang, Y., A. Jaffa, S. Koskinen, A. Takei, and M. F. Lopes-Virella. 1999. Oxidized LDL-containing immune complexes induce Fc gamma receptor I-mediated mitogen-activated protein kinase activation in THP-1 macrophages. *Arterioscler. Thromb. Vasc. Biol.* **19**: 1600-1607.
- Lowry, O. H., N. J. Rosebrough, A. L. Farr, and R. J. Randall. 1957. Protein measurement with the folin phenol reagent. *J. Biol. Chem.* **193**: 265-275.
- Garnovskaya, M. N., Y. Mukhin, and J. R. Raymond. 1998. Rapid activation of sodium-proton exchange and extracellular signal-regulated protein kinase in fibroblasts by G protein-coupled 5-HT1A receptor involves distinct signaling cascade. *Biochem. J.* **330**: 489-495.
- Su, B., and M. Karin. 1996. Mitogen-activated protein kinase cascades and regulation of gene expression. *Curr. Opin Immunol.* **8**: 402-411.
- Kotzka, J., D. Muller-Wieland, G. Roth, L. Kremer, M. Munck, S. Schurmann, B. Knebel, and W. Krone. 2000. Sterol regulatory element binding proteins (SREBP)-1a and SREBP-2 are linked to the MAP-kinase cascade. *J. Lipid Res.* **41**: 99-108.
- Dhawan, P., A. Bell, A. Kumar, C. Golden, and K. D. Mehta. 1999. Critical role of p42/44MAPK activation in anisomycin and hepatocyte growth factor-induced LDL receptor expression: activation of Raf-1/MEK-1/p42/44MAPK cascade alone is sufficient to induce LDL receptor expression. *J. Lipid Res.* **40**: 1911-1919.
- Singh, R. P., P. Dhawan, C. Golden, G. S. Kapoor, and K. D. Mehta. 1999. One-way cross-talk between p38 (MAPK) and p42/44 (MAPK). Inhibition of p38 (MAPK) induces low density lipoprotein receptor expression through activation of the p42/44 (MAPK) cascade. *J. Biol. Chem.* **274**: 19593-19600.